

LGLH-37 GSL
Bain-marie

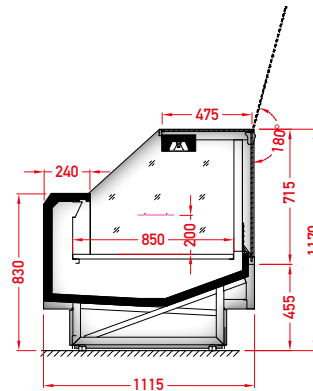

LGLH-37 GSL
Hot-plate

STANDARD FEATURES

- hot cases: Bain Marie/Hot plate
- temperature up to 85°C
- electronic controller with temperature indicator / for Bain Marie additionally a mechanical thermometer at the air inlet
- feature of the heating element – heating plate (for hot case) / heating bath (for Bain Marie)

OPTIONS

- sidewalls
- bumper

GSL – glass | single, straight | lift up

AVAILABLE MODULES

GSL 1250 1875 Hot-plate
0938 1250 Bain-marie

